



LS ULTRACAPACITOR

Power Up your Energy Storage with LS Ultracapacitors

LS ULTRACAPACITOR

LS Materials
www.lsmaterials.co.kr
www.ultracapacitor.co.kr



Contact Information | E-mail : sp.jeong@lsmaterials.co.kr

LS Mtron Tower, 39, 116 beon-gil, LS-ro, Dongan-gu, Anyang-si, Gyeonggi-do, 14118, Korea

© 2023 LS Materials Co., Ltd. All right reserved. This product or document is protected by copyright and distributed under licenses restricting its use, copying, distribution, and decompilation. No part of this product or document may be reproduced in any form by any means without prior written authorization of LS Materials and its licensors, if any.

LS Materials Co., Ltd. All right reserved **December, 2023**

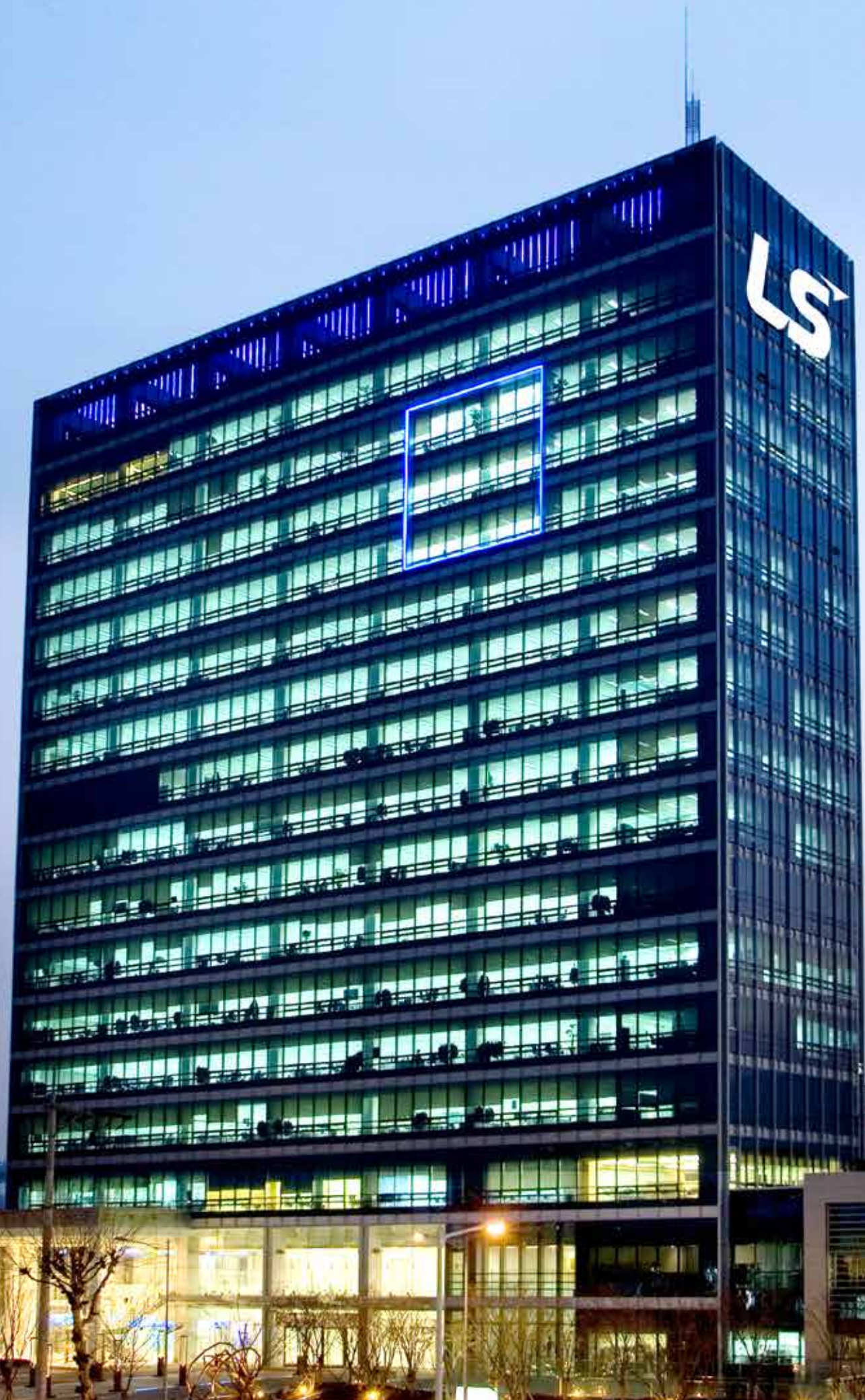

Vision Statement

In order to become a leader in the competitive global market LG has been divided into three business groups based upon their core competencies, Industrial Electric-Electronic Energy & Materials(LS), Electronic & Chemical(LG), and Energy & Retail(GS).

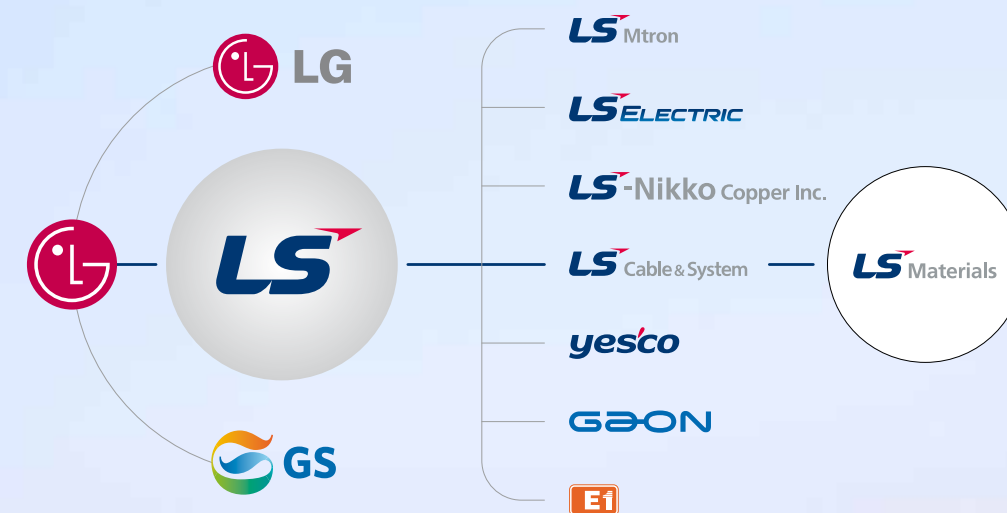

Leading Power Storage Partner - LS Materials

Ultracapacitor division split off from LS Mtron in January, 2021, incorporated a new company named LS Materials in order to solely focus its resources and human capital in the ultracapacitor business. LS has been engaged in research & development, and production of ultracapacitor cells and modules for 20 years, leading the market with its cutting edge power storage solution. It has been serving top tier customers in sectors ranging from renewable energy, industrial automation, to power quality management and automotive. LS Materials, taking over the baton from LS Mtron, will continue the relentless endeavors to develop and provide the most cost-effective power solutions to all of existing and potential customers all across the world.



LS ULTRACAPACITOR

LS Ultracapacitor energy storage devices are positioned between conventional electrolytic capacitors and rechargeable batteries. LS Ultracapacitors feature high power, high energy, reliability and long life which enables use in a variety of applications such as back-up power, auxiliary power, instantaneous power compensation and peak power compensation.

- Rated voltage : up to 3.0V
- High power performance (vs. Battery)
- High energy performance (vs. Conventional electrolytic capacitor)
- Environmentally friendly
- Maintenance-free
- Wide operating temperature range (-40°C ~ +65°C)



• OHSAS18001:2007



• UL Certification



• IATF 16949



• ISO 14001:2015

Introduction to LS Ultracapacitor Technology

Ultracapacitor VS LIB

Structure

An Ultracapacitor consists of two electrodes immersed in an electrolyte and a separator which prevents the charge from moving between two electrodes of opposite polarity.

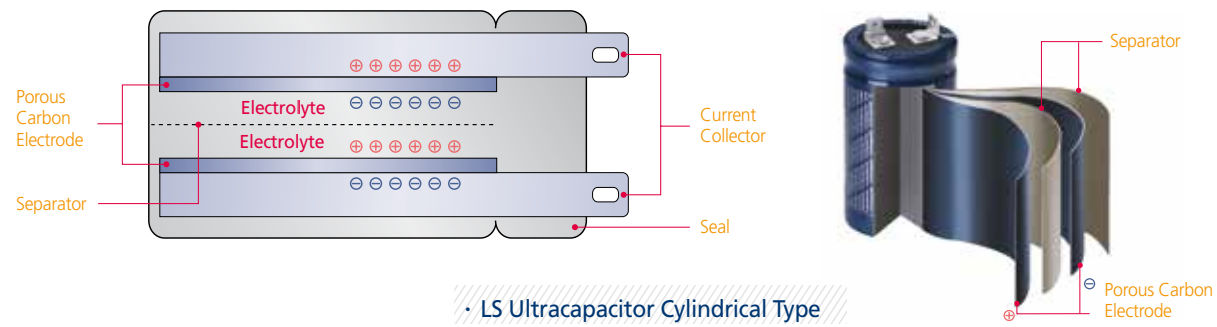

· LS Ultracapacitor Cylindrical Type

LS Materials provides optimal package design to provide the best in performance and reliability.

High Energy & High Power

Ultracapacitors are unique energy storage devices offering high power and high energy simultaneously, compared with conventional electrolytic capacitors and batteries. The high energy stored by Ultracapacitors in comparison to conventional electrolytic capacitors is derived from activated carbon electrode material having the extremely high surface area and the short distance of charge separation created by the opposite charges in the interface between electrode and electrolyte.

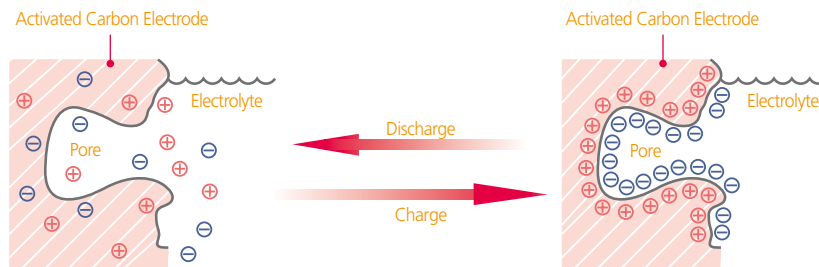

High power, long shelf and cycle life performance of Ultracapacitors originate in the energy storage mechanism differing from batteries. With batteries, energy is stored and released via chemical reaction inside electrode material that causes degradation of the entire system. On the other hand, Ultracapacitors use physical charge separation phenomena between the charge on an electrode and ions in electrolyte at the interface. Since the charge and discharge processes are purely physical and highly reversible, Ultracapacitors can release energy much faster and with more power compared to batteries which rely on slow chemical reactions and can be cycled hundreds of thousands of times without significant effect on performance.

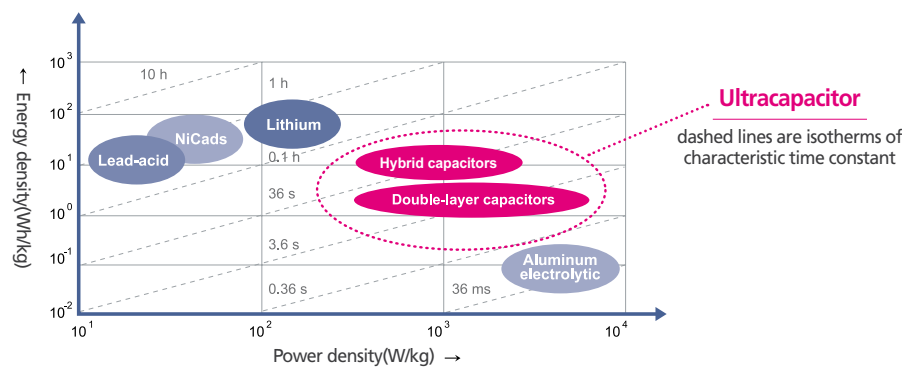

Ultracapacitor



Fast and Versatile

Physical absorption-desorption

- Specific energy : ~15 W-h/kg
- Operation Temperature : -40 ~ 85°C
- Charge/discharge efficiency : 99.2 ~ 99.8 %
- Specific Power : ~ 18 kW/kg
- Cycle durability : 1000k Cycles

· Ultracapacitor

Li-ion Battery



High Energy

Chemical reaction

- Specific energy : ~200 W-h/kg
- Operation Temperature : 0 ~ 45°C
- Charge/discharge efficiency : 80~90%
- Specific Power : ~0.2 ~ 0.4 kW/kg
- Cycle durability : 0.4k Cycles (100% DoD basis)

· Li-ion Battery

Ultracapacitor + Li-ion Battery



By combining Ultracapacitor and Li-ion battery

Ultracapacitor provides substantial benefits in terms of performances battery life and energy economy

- To improve the application efficiency and energy economy over variable operating conditions
- To assure reliable performance and fast response even with battery degradation
- To extend battery life by shaving peak load



Cell

LS Materials has more than 45 types of cells in mass production

22Ø Series PCB mounting type cell

Series	Rated Voltage	Capacitance	Part No.	Max. ESR(DC)	Max. Current	Leakage Current	Max. Stored Energy	Weight	Type	Dimension Ø x mm
	V	F		mΩ	A	mA	Wh	kg		
22 Ø	2.8	100	LSUC 002R8S 0100F EA	9.0	74	<0.3	0.10	0.023	Snap-in	22 x L46
		120	LSUC 002R8S 0120F EA	9.0	81	<0.4	0.13	0.023		
	3.0	100	LSUC 003RDS 0100F EA	7.0	88	<0.3	0.13	0.023	Lug	22 x L46

33Ø Series PCB mounting type cell

Series	Rated Voltage	Capacitance	Part No.	Max. ESR(DC)	Max. Current	Leakage Current	Max. Stored Energy	Weight	Type	Dimension Ø x mm
	V	F		mΩ	A	mA	Wh	kg		
33 Ø	2.8	360	LSUC 002R8L 0360F CU03	3.2	234	<1.0	0.39	0.065	Lug	33 x L61

35Ø Series PCB mounting type cell

Series	Rated Voltage	Capacitance	Part No.	Max. ESR(DC)	Max. Current	Leakage Current	Max. Stored Energy	Weight	Type	Dimension Ø x mm
	V	F		mΩ	A	mA	Wh	kg		
35 Ø	2.8	320	LSUC 002R8L 0320F EM	2.0	273	<1.0	0.34	0.078	Lug	35 x L61
		350	LSUC 002R8L 0350F EA	3.2	231	<1.0	0.38	0.072		
		400	LSUC 002R8L 0400F EA	3.0	255	<1.0	0.43	0.080		
		Lug or Snap-in	450	LSUC 002R8L 0450F EA	3.0	268	<1.0	0.49	0.088	
			600	LSUC 002R8L 0600F EA	3.2	288	<1.3	0.65	0.090	
			720	LSUC 002R8L 0720F EA	2.0	413	<1.5	0.78	0.130	
3.0	360	LSUC 003ROL 0360F LE	1.7	335	<1.0	0.45	0.080	Lug	35 x L61	
	380	LSUC 003ROL 0380F EA	3.2	257	<1.0	0.47	0.072	Lug or Snap-in	35 x L61	
	430	LSUC 003ROL 0430F EA	3.0	282	<1.0	0.53	0.080			
480	LSUC 003ROL 0480F EA	3.0	295	<1.2	0.60	0.088	Lug	35 x L71		

60Ø Series Busbar connection type cell

Series	Rated Voltage	Capacitance	Part No.	Max. ESR(DC)	Max. Current	Leakage Current	Max. Stored Energy	Weight	Type	Dimension Ø x mm
	V	F		mΩ	A	mA	Wh	kg		
60 Ø	2.7	650	LSUC 002R7C 0650F NH	0.57	640	<1.5	0.65	0.200	Cylindrical	60 x L138
		1200	LSUC 002R7C 1200F NH	0.33	1160	<2.7	1.21	0.280		
		1500	LSUC 002R7C 1500F NH	0.28	1426	<3.0	1.51	0.320		
		2000	LSUC 002R7C 2000F NH	0.27	1753	<4.0	2.02	0.380		
		3000	LSUC 002R7C 3000F NH	0.23	2396	<5.0	3.03	0.515		
		2.85	3400	LSUC 02R85C 3400F NH	0.23	2719	<8.0	3.83		
3.0	3000	LSUC 003ROC 3000F NH	0.23	2663	<5.0	3.75	0.515			
	3400	LSUC 003ROC 3400F NH	0.20	2800	<8.0	4.25	0.515			

• Max. Current : Non-repeated (Calculated value)
 • Operating Temperature Range : -40 ~ 65°C

Products



• 22/33/35 Ø Series Cell

Lug & Snap-in Terminal Type (22/33/35 Ø Series)



• Snap-in (100F/120F) • Lug (320F ~ 720F) • Snap-in (4pin, 350F ~ 720F)



• 60 Ø Series Cell

Cylindrical Terminal Type (60 Ø Series)



• Short Screw (ST01) • Weldable (WT01) • Long Screw (LT01) M16 Terminal • Long Screw (LT02) M12 Terminal

Cell/Module Part No. Rule

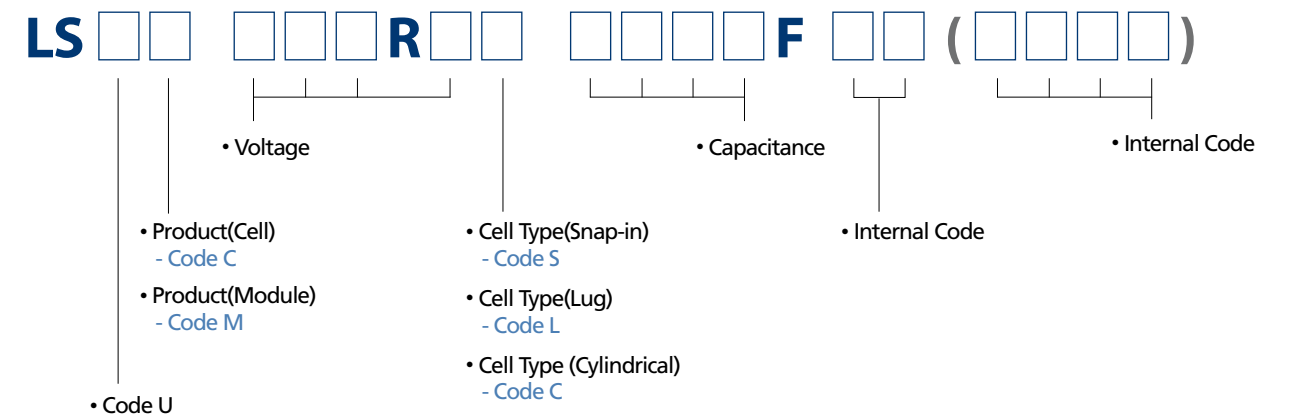

Module

LS Materials has more than 20 types of modules in mass production

PCB type series

PCB type Series is modules built up with 22 ϕ & 33 ϕ series cells on PCB board

Part No.	Rated Voltage	Capacitance	Max. ESR(DC)	Max. Continuous Current	Leakage Current	Stored Energy	Weight	Balancing	Monitoring	Dimension
	V	F	m Ω	A	mA	Wh	kg			L x W x H (mm)
LSUM 016R8L 0058F EA	16.8	58	22	20	<11.0	2.3	0.7	Active or Passive	-	245 x 47 x 76.6
LSUM 168ROL 0005F EA	168	5.8	240	12	<25.0	22.7	6.5	Passive	Temperature(NTC)/Half Voltage monitoring	235 x 367 x 79



LSUM 016R8L 0058F EA



LSUM 168ROL 0005F EA

Busbar type series

Busbar type Series is modules built up with 60 ϕ series cells connected with busbar

Part No.	Rated Voltage	Capacitance	Max. ESR(DC)	Max. Continuous Current	Leakage Current	Stored Energy	Weight	Balancing	Monitoring	Dimension
	V	F	m Ω	A	mA	Wh	kg			L x W x H (mm)
LSUM 016R2C 0500F EA	16.2	500	1.5	200	<5.0	18.2	5.6	Active or Passive	Temperature(NTC)	67.2 x 416.2 x 175.9
LSUM 032R4C 0250F EA	32.4	250	3.3	150	<11.0	36.5	10.0	Passive	-	137.1 x 426.6 x 184
LSUM 048R6C 0166F EA DC	48.6	166	4.4	130	<5.0	54.5	14.0	Active or Passive	Temperature(NTC)/Over Voltage	194.5 x 419.5 x 177
LSUM 051R3C 0166F EA	51.3	166	5.0	100	<28.5	60.7	12.0	Active and Passive	Temperature(PTC)/Over Voltage	590.4 x 136 x 171
LSUM 086R4C 0093F EA	86.4	93	11.3	80	<120.0	96.4	27.0	Passive	Temperature(PT100)	517 x 265 x 210.5
LSUM 129R6C 0062F EA	129.6	62	11.5	240	<10.0	144.6	55.0	Active or Passive	Temperature & Group Voltage(CAN 2.0B)	720 x 405 x 226



LSUM 016R2C 0500F EA



LSUM 032R4C 0250F EA



LSUM 048R6C 0166F EA DC



LSUM 051R3C 0166F EA



LSUM 086R4C 0093F EA



LSUM 129R6C 0062F EA

- Leakage Current can be changed by Balancing method
- NTC Thermistor & Group voltage monitoring is analog method
- Customized module can be supplied under the customer's requirement
- Max Continuous Current : $\Delta T = 40^{\circ}C$
- Max Continuous Current may be different depending on the cooling method

CTC Description

CTC (Cell to Cell) series module can be made up with connected cells (60 ϕ Series cell) at customer's request
The CTC module can be made from 16V up to 108V without additional development with extendable module case



Monitoring for CTC series module

Temperature sensor	Temperature interface	Connector	Cell voltage monitoring	Balancing
NTC Thermistor	Analog	4pin	OVA(Optional)	Active or Passive

CTC series

CTC (Cell To Cell) series module is available from 16V to 108V, is extendable and customizable without additional costs to the customer

Part No.	Adapted Cell Module			Rated Voltage	Capacitance	Max. ESR(DC)	Max. Continuous Current	Leakage Current	Stored Energy	Weight	Dimension
	Rated Voltage	Capacitance	Series								
	V	F									
LSUM 048R6C 0066F EA YJ	2.7	1200	18	48.6	66	7.2	160	<2.7 (Active)	21.7	10.3	279 x 418 x 71
LSUM 064R8C 0050F EA YJ			24	64.8	50	9.6	130	<27 (Passive)	29.1	13.2	362 x 418 x 71
LSUM 048R6C 0083F EA YJ			18	48.6	83	6.1	180	<3.0 (Active)	27.2	11.5	312 x 418 x 71
LSUM 064R8C 0062F EA YJ		24	64.8	62	8.1	140	<27 (Passive)	36.1	14.8	406 x 418 x 71	
LSUM 048R6C 0111F EA YJ		18	48.6	111	5.9	180	<4.0 (Active)	36.4	13.5	363 x 418 x 71	
LSUM 064R8C 0083F EA YJ		24	64.8	83	7.8	150	<27 (Passive)	48.4	17.5	474 x 418 x 71	
LSUM 048R6C 0166F EA YJ		18	48.6	166	4.4	200	<5.0 (Active)	54.5	17.2	471 x 418 x 71	
LSUM 064R8C 0125F EA YJ		24	64.8	125	5.8	160	<27 (Passive)	72.9	22.5	618 x 418 x 71	
LSUM 016R2C 0250F EA AG		2.7	1500		250	2.0	150	<3.0 (Active) <27 (Passive)	9.1	3.9	311 x 166 x 70
LSUM 016R2C 0500F EA AG				6	16.2	500	1.5	200	<5.0 (Active) <27 (Passive)	18.2	5.9



LSUM 048R6C 0166F EA YJ



LSUM 016R2C 0500F EA AG



LSUM 016R2C 0250F EA AG

Ultracapacitor Biz. History

Longest history in the ultracapacitor industry
 LS ultracapacitor has 21 years of history in the ultracapacitor industry

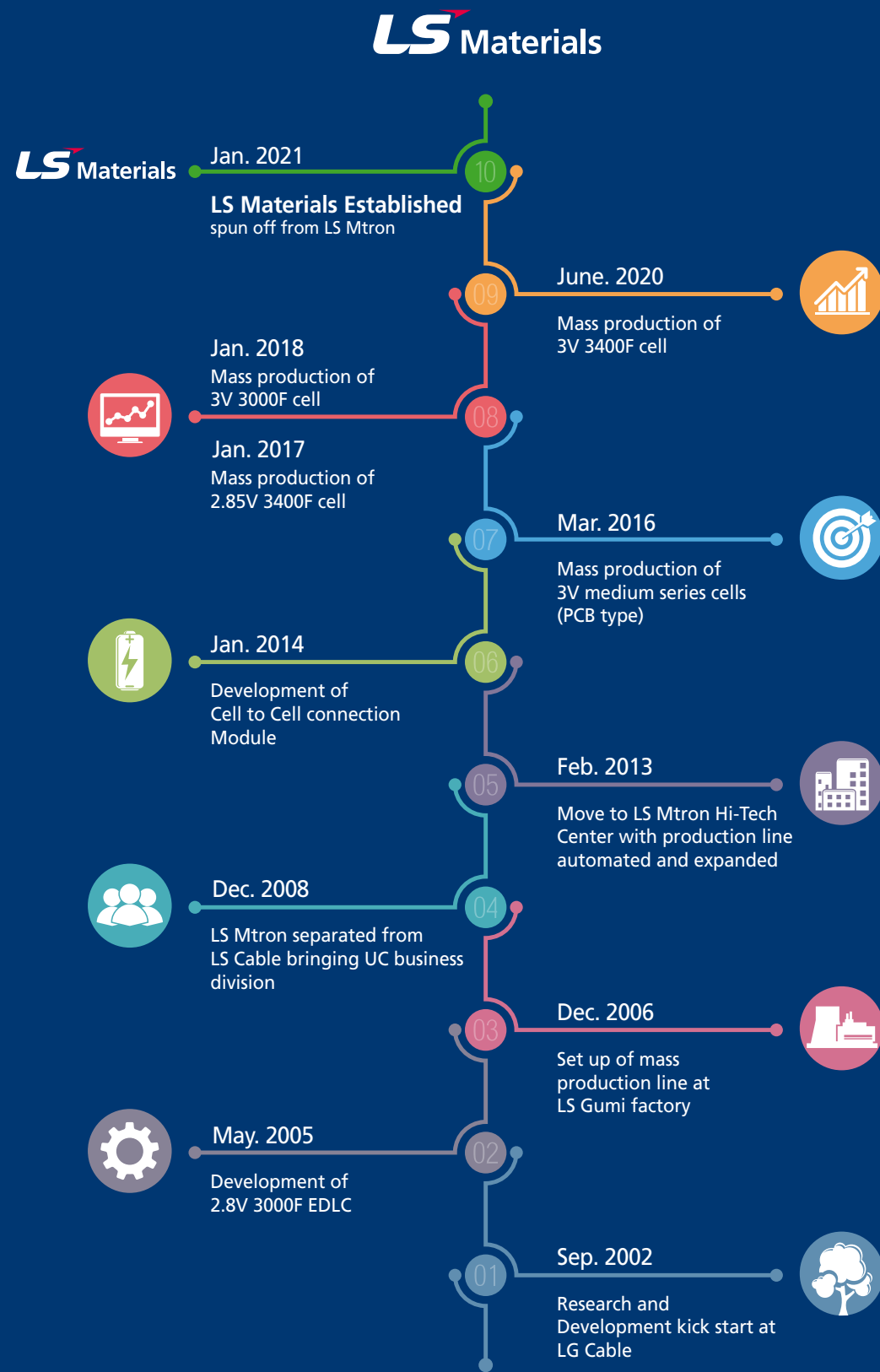

Markets for LS Ultracapacitors



AGV

- Numerous charge & discharge cycles, long life span
- Peak power shaving, minimizing power infrastructure investment
- Energy saving



Wind Turbine

- Maintenance free in all environments and long service life
- Ultra-safe, eliminating concerns for fire or explosion



Power Quality Solution (UPS)

- Instant back up for voltage sag or dip
- Maintenance free for up to 20 years
- Ultra-safe, eliminating concerns for fire or explosion



Hybrid Heavy Equipment

- Peak power shaving, downsizing motor and engine requirement
- Improve fuel economy and meet emission regulations
- Long service life and maintenance free



Passenger Car and Vehicle

- Stabilize DC power supply and extend battery life
- Improve fuel economy by reducing alternator loadings
- Jumpstart in all seasons



Transportation

- Numerous charge & discharge cycles, maintenance free
- Capture regenerative braking energy, improving energy efficiency
- Ultra-safe, eliminating concerns for fire or explosion



Hybrid Harbor Crane

- Peak shaving and reduction, improving crane reliability
- Significant savings in power infrastructure investment
- Long term return in energy savings



HEV (Hybrid Electric Vehicle)

- Provide peak power, extending battery life
- Capture regenerative braking energy
- Jumpstart in all seasons

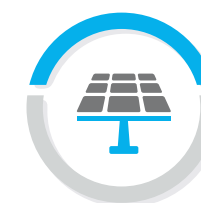

Photovoltaic and Solar Lighting

- Provides a reliable ESS solution in extreme environments
- Long service life and maintenance free



Power Grid

- Improving inertia for power grid of renewable energy
- Supplying active power to power grid
- Space-saving compared to LIB due to the ultracapacitor's high power



ESS

- Reduction maintenance cost by initial output power and long life cycle
- Ultra-safe, eliminating concerns for fire or explosion



Railway Signal

- Outstanding operating temperature range (-45°C ~ 60°C)
- Reduction maintenance cost due to its numerous charge & discharge cycles

LS Materials Sales Network



Capability



- Mid size cell : 6M/Yr
- Cylindrical cell: 1.5M/Yr

Major Plants



- Global No.1 ultracapacitor manufacturer
- Develop high-voltage, ultra-low resistance products, and new technology-applied modules

LS Tower, Hi-Tech Center, 2nd Factory



Head office, Ultracapacitor plant